

VBW9 FAN SPECIFICATIONS

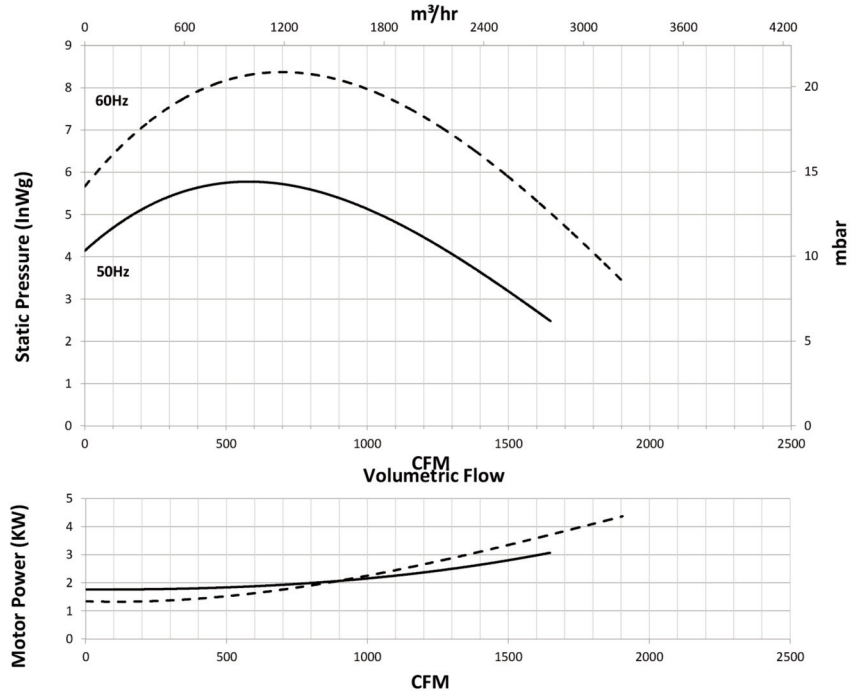

[Please note - image above may not be representative of the unit supplied]

Motor type:	Squirrel cage induction motor IP55 as std
Nominal supply:	380/420VY / 220/240VD 3Ph 50Hz 440/480VY / 250/280VD 3Ph 60Hz 1Ph available
Options:	Inlet & discharge guards, Inlet filters, Spigots
Materials:	Fancase: Cast aluminium LM6 Impellers: Galvanised sheet steel
Finishes:	Unpainted/Stove enamel (black) as std
Mounting options:	Motor feet or Pedestal
Noise levels:	94dB(A) for 2 Pole, Free Air, 1M 73dB(A) for 4 Pole, Free Air, 1M
Weight:	30Kgs / 66Lbs
Motor Variations:	ATEX, CE, CSA, UL available



Outline dimensions:

[Note: motor shown is for 50Hz performance.
 Motor dimensions for 60Hz operation may vary]

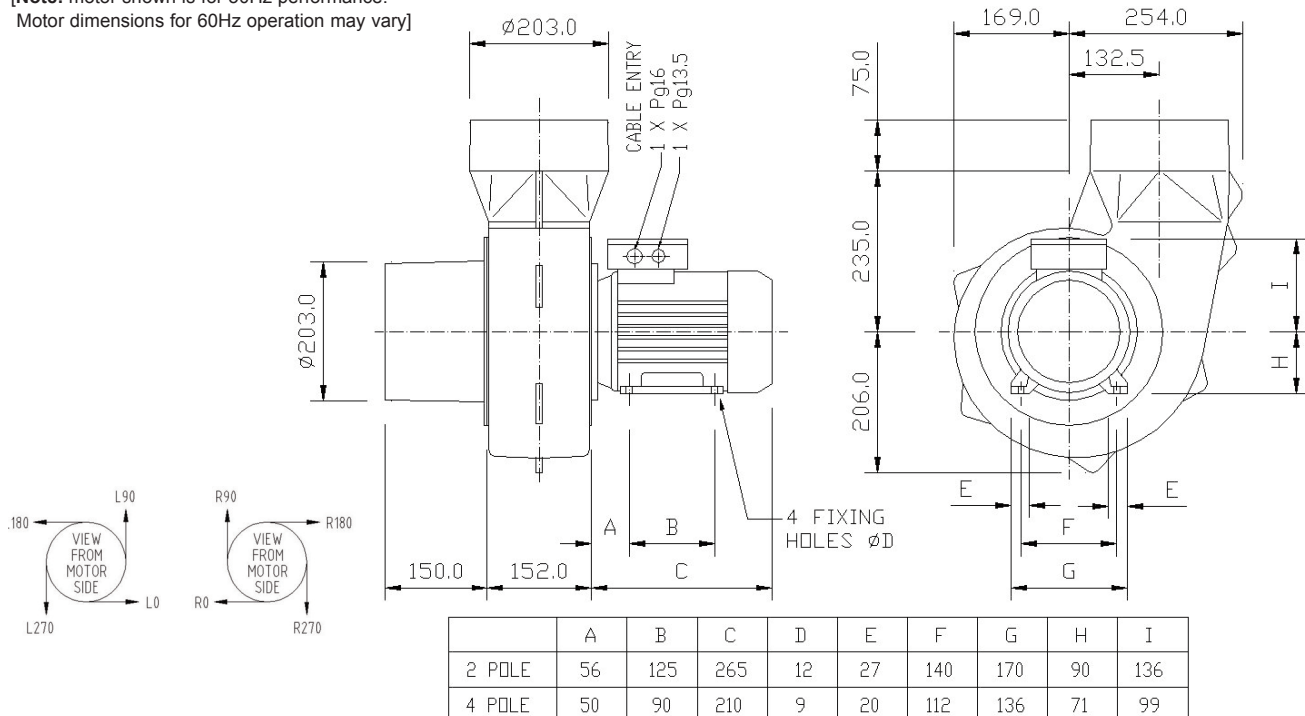

Please note (1) - all drawings measurements are in millimeters (mm)
 Please note (2) - above technical specifications are subject to change